

Swimming Pool Operating Guidelines





SAA Template

Swimming Pool Guidelines

1.	Introduction	3
1.1.	Background	3
2.	COVID-19 Safety Requirements	4
2.1.	Revised Club Times	4
2.2.	Prior to Pool Night	4
2.3.	Entry to the building	4
2.4.	Pool and Surrounding Area	5
2.5.	Exit from the building	5
2.6.	Use of Equipment	5
3.	Name of Club – Risk Assessment	7
4.	Pool Configuration – Current Usage	15
5.	Pool Configuration – COVID-19 Restrictions with no Swimmers	16
6.	Pool Configuration – COVID-19 Restrictions with Swimmers	17
7.	Poolside Storage of Club Equipment	18
8.	Swimming Pool – Operating Procedures	19



SAA Template

Swimming Pool Guidelines

1. Introduction

This sample pool guidelines has been produced to provide clubs with guidance in documenting the changes required for the return by clubs to swimming pools. Parts of this document can be used with little or no change whereas other parts will be very specific to your own pool. When producing your own club guidelines you must work with your pool management and ensure that there both comply with the revised pool arrangements and are agreed with the pool management.

This document is based on one which has been reviewed by the local council H&S department and leisure centres manger.

This will not be set in stone and you will need to review of a regular basis to reflect things as they change.

Finally when your document has been agreed you will need to share this with all of your club members.

Any questions email admin@saa.org

The **name** of Club has been meeting at the **name** Swimming Pool for **whatever** years. Until the outbreak of the Coronavirus pandemic the club operated under the provisions of **Swimming Pool's** Standard Operating Procedures (SOPs) and the Emergency Operating Procedures (EOPs) together with guidance from the Sub Aqua Association, the clubs governing body and UK federation of CMAS (World Underwater Federation).

This new set of guidelines has been produced to both document how the club operators within the pool environment, as agreed with the **Swimming** Pool management, with details of the additional requirements as a result of the Coronavirus pandemic, and to provide club members with an additional guidance to keep them safe at this time.

DO Name

Diving Officer
Diver Grade
Instructor Grade & Number

1.1. Background

Optional section for whatever you want



SAA Template

Swimming Pool Guidelines

2. COVID-19 Safety Requirements

The **Name of Club** derives its COVID-19 guidance from the BDSG (British Diver Safety Group) Web Site (<https://bdsg.org.uk/>) which is a repository for a wide ranging advice covering all aspects of UK diving and divers.

The BDSG consists of representatives from all dive and national agencies including the RNLI, HSE, MCA and UKDMC to name just a few.

2.1. Revised Club Times

To meet covid-19 requirements the club has agreed to move our times to 20:30hrs to 21:30hrs during the period of the pandemic. This is to allow the pool staff 30 minutes between sessions to undertake full cleaning of the pool area.

During the special arrangements club members will not be allowed into the pool building without prior agreement with the pool management.

2.2. Prior to Pool Night

Before arriving at the pool members will confirm their plans for the evening, with the Pool Marshal, these must reflect:

- If, as an individual, you wish to use the pool to swim. There will be a requirement to mark off two lanes for a maximum of **seven** swimmers.
- If no-one books a swimming slot the area will not be marked off so that the whole pool area is open to divers.
- Anyone snorkelling will be regarded as swimmers at this time.
- Instructors will liaise with their trainees to discuss which skills they will be practising during the next pool session.
- The maximum number of divers in the whole pool is **fifteen**, this is reduced to **ten** when the swimming area is in place.
- If anyone wants to remain on the poolside during the session must also book a place as the pool has limited the number of spectators at any time to **four**.

If the pool occupancy level exceeds that numbers allowed the Pool Marshal will allocate slots so that all members who want to use the pool will have at least some time each Friday.

2.3. Entry to the building

When planning to use the pool club members should:

- You must not attend the pool if you or any member of your household are showing signs of COVID-19 symptoms, these include any one of the following:
 - **a high temperature** – this means you feel hot to touch on your chest or back (you do not need to measure your temperature)
 - **a new, continuous cough** – this means coughing a lot for more than an hour, or 3 or more coughing episodes in 24 hours (if you usually have a cough, it may be worse than usual)
 - **a loss or change to your sense of smell or taste** – this means you've noticed you cannot smell or taste anything, or things smell or taste different to normal



SAA Template

Swimming Pool Guidelines

- At all times maintain the required social distance which is in force at the time, including wearing any recommended PPE (e.g. face coverings)
- Before travelling to the pool you should shower at home, this will help with the pool water quality and the water treatment process.
- Travel to the pool wearing their pool kit.
- If diving in the pool any required pre-brief should be conducted in the car park.
- Kit should be assembled in the car park and carried into the pool ready assembled.
- The Pool Marshal will allocate an order in which each Buddy Team can enter the building, the route into and out of the pool area are shown in Section 6 Pool Configuration – COVID-19 Restrictions with Swimmers
- Once in the designated area members should remove their outer clothing which should be placed in a bag.

2.4. Pool and Surrounding Area

When in the pool area remember the social distancing rules, particularly:

- Swimmers to maintaining social distance in line with **Swimming** pool guidelines.
- Divers:
 - While on the surface and poolside should maintain social distance in-line with those in force for swimmers
 - While underwater there is no need to social distance as the virus cannot be transmitted underwater.

2.5. Exit from the building

When leaving the pool club members should:

- Members bags with their outer clothing will be moved from the entry point to the pool exit end by the Pool Marshal.
- Exit from the pool, as indicated in Section 6 Pool Configuration – COVID-19 Restrictions with Swimmers.
- Under current guidelines swimmers etc. are advised to simply don their cloths and shower when they get home. In view of this divers may wish to wear swimming wear under their normal diving clothes which is easier to dry off while wearing and will carry less water into the car.
- Kit should be dismantled in the car park.

2.6. Use of Equipment

When using snorkeler or SCUBA equipment members should take the following into account:

- Use of a snorkel
 - The use of forceful clearing of the snorkel carries a high risk of virus transmission due to the potential for atomisation of the expired air being capable of being carried further than normal. Snorkelers will not use this method.
 - Snorkels fitted with a purge valve will reduce the problem as the water if dispelled into the pool water



SAA Template

Swimming Pool Guidelines

- If using a snorkel without a purge valve use the displacement method to clear, that is blow the water out of the snorkel while underwater with the snorkel pointing down.
- The chlorinated water is known to kill the virus over a relatively short period of time. This will in effect disinfect a divers kit during a normal session underwater.
- When leaving the pool it is recommend that all divers swill their mask and regulator in the pool water, this will not disinfect completely as the immersion time will not be sufficient, but provides a limited level of protection until they are disinfected at home.



SAA Template

Swimming Pool Guidelines

3. Name of Club – Risk Assessment

The **Name of Club** follows the guidance provided by the HSE in determining and managing risks to the club members, these include the following key steps:

- 1) Identify hazards
 - a. Review all the activities undertaken by the club and its members and visitors
- 2) Assess the risks
 - a. Who might be harmed and how
 - b. What we are already doing to control the risks
 - c. What further action we need to take to control the risks
 - d. Who needs to carry out any actions and by when
- 3) Control the risks
 - a. Can the risk be removed completely
 - b. If not can the risk be mitigated to be at an acceptable level
- 4) Record our findings
 - a. The hazards (things that may cause harm)
 - b. Who might be harmed and how
 - c. What you are doing to control the risks
- 5) Review the controls
 - a. Are the controls still effective
 - b. Has there been any changes

This Risk Assessment was last review on the **29th June 2020** by **Name (Position in Club)**

Next scheduled full review date is **1st August 2021 (should be reviewed every 12 months)**

What are the hazards?	Who might be harmed and how?	What are you already doing to control the risks?	What further action do you need to take to control the risks?	Who needs to carry out the action?	When is the action needed by?	Done

SAA Template

Swimming Pool Guidelines



What are the hazards?	Who might be harmed and how?	What are you already doing to control the risks?	What further action do you need to take to control the risks?	Who needs to carry out the action?	When is the action needed by?	Done
COVID-19 Risk 1 Access to and from the pool.	All Individuals may become infected with the COVID-19 Virus.	Nothing new risk	Members will not attend if they or anyone from their household are showing signs of COVID-19. The club will appoint a Pool Marshal who will manage the flow of club members into the pool building and onto the pool area.	Club Diving Officer supported by members of the club committee.	By return to the pool.	
COVID-19 Risk 2 Risk to pool users	All Individuals may become infected with the COVID-19 Virus.	Nothing new risk	Mitigation of this risk falls into three areas: 1. Swimmers – These will follow the revised guidelines for swimmers as documented in the Swimming Pool SOP. 2. Snorkelers – will follow the guidance for swimmers. 3. Divers – Must maintain social distance while on the surface. Also see additional guidance on use equipment in the pool.	Nominated Club Pool Marshall.	By return to the pool.	

SAA Template

Swimming Pool Guidelines



What are the hazards?	Who might be harmed and how?	What are you already doing to control the risks?	What further action do you need to take to control the risks?	Who needs to carry out the action?	When is the action needed by?	Done
COVID-19 Risk 3 Risk to pool users	Divers Infection whilst underwater	Nothing new risk	There is no evidence that the virus can be transmitted underwater, therefore there is no need to maintain social distancing while underwater. The chlorinated water is known to kill the virus.	Club Diving Officer.	By return to the pool.	29/06/2020
COVID-19 Risk 4 Risk to spectators	All Individuals may become infected with the COVID-19 Virus.	Nothing new risk	The number of any spectators will be limited to the maximum allowed under the Swimming pool SOPs. Club Name will operate a weekly booking system to ensure the numbers are correctly managed.	Club Diving Officer supported by members of the club committee.	By return to the pool.	
COVID-19 Risk 5 Use of shared club equipment	Trainee: a) Scuba Divers b) Snorkeller c) Ad hoc by club members.	Nothing new risk	No equipment will be used unless it has been fully disinfected.	Equipment Officer who may delegate to the Instructor or Dive Leader who has responsibility for the individual using the kit.	By return to the pool.	

SAA Template

Swimming Pool Guidelines



What are the hazards?	Who might be harmed and how?	What are you already doing to control the risks?	What further action do you need to take to control the risks?	Who needs to carry out the action?	When is the action needed by?	Done
COVID-19 Risk 6 SCUBA divers exhaust contains the virus	ALL Anyone on the surface above the divers.	Nothing new risk	The “diving area” will be kept clear of surface swimmers. Divers on the surface should kept their mask and regulator in place.	Instructors and Dive Leaders to ensure divers stay safe at all times	By return to the pool	30/06/2020
Ear damage	All SCUBA Divers Burst Ear drum	All Scuba Divers are taught to clear their ears on descent. At 2.3 metres maximum depth the risk is low at this pool.	No further action is required.	N/A	N/A	N/A
Mask squeeze	Trainee SCUBA Divers Black Eye	All Scuba Divers are taught to equalise their masks on descent. At 2.3 metres maximum depth the risk is low at this pool.	No further action is required.	N/A	N/A	N/A



What are the hazards?	Who might be harmed and how?	What are you already doing to control the risks?	What further action do you need to take to control the risks?	Who needs to carry out the action?	When is the action needed by?	Done
Mask glass breakage	SCUBA Divers & Snorkelers Lacerations	Extremely rare event, trainees are advised to buy main stream dive masks with tempered glass. Risk increases with cheap imported masks.	No further action is required.	N/A	N/A	N/A
Panic	Trainee SCUBA Divers Leading to rapid ascent while breath holding.	See – <ul style="list-style-type: none"> • Rapid ascent • Breath holding while on SCUBA 	No further action is required.	N/A	N/A	N/A
Rapid ascent	Burst Lung	With a maximum depth of 2.3 metres this is not a likely event in the <i>Swimming</i> pool.	No further action is required.	N/A	N/A	N/A
Breath holding while on SCUBA	Trainees Burst Lung & Embolism	All SCUBA divers are taught not to hold their breath at any time when breathing from SCUBA equipment.	No further action is required.	N/A	N/A	N/A

SAA Template

Swimming Pool Guidelines



What are the hazards?	Who might be harmed and how?	What are you already doing to control the risks?	What further action do you need to take to control the risks?	Who needs to carry out the action?	When is the action needed by?	Done
Running out of air	All Scuba Divers May result in a rapid ascent while breath holding.	Divers to ensure that they have sufficient air at the start of the session. Depth of pool and duration of the session makes this an unlikely event. See also – <ul style="list-style-type: none">• Rapid ascent• Breath holding while on SCUBA	No further action is required.	N/A	N/A	N/A
Drowning	All Death	Pool is staffed by lifeguards supplemented by the clubs instructors and pool marshal who are in a position to quickly respond.	No further action is required.	N/A	N/A	N/A
Slipping	All Broken limbs	All pool users will: <ul style="list-style-type: none">• Refrain from running on the poolside.• Take extra care when handling and carrying heavy SCUBA equipment.	No further action is required.	N/A	N/A	N/A

SAA Template

Swimming Pool Guidelines



What are the hazards?	Who might be harmed and how?	What are you already doing to control the risks?	What further action do you need to take to control the risks?	Who needs to carry out the action?	When is the action needed by?	Done
Falling cylinders	All Crushed bones	All SCUBA Divers are instructed to lay down unattended cylinders. Instructors will remind trainees as necessary.	No further action is required.	N/A	N/A	N/A
Collision by swimmers with SCUBA divers	All Injury inflicted to swimmer by impact with cylinder valve and/or regulator	All swimmers: a] wear a mask or pair of goggles to provide clear vision under the water. b] Will only use breast stroke so as to ensure they can see divers under the water. c] will remain in the cordoned off swimming area where this is available.	No further action is required.	N/A	N/A	N/A

SAA Template
Swimming Pool Guidelines



What are the hazards?	Who might be harmed and how?	What are you already doing to control the risks?	What further action do you need to take to control the risks?	Who needs to carry out the action?	When is the action needed by?	Done
Heart Attack	All Death	All SCUBA Divers are required to complete a medical declaration. The leisure centre trained First Aiders are on site at all times to administer first aid. AED available in the reception area of the pool.	No further action is required.	N/A	N/A	N/A

SAA Template
Swimming Pool Guidelines



4. Pool Configuration – Current Usage

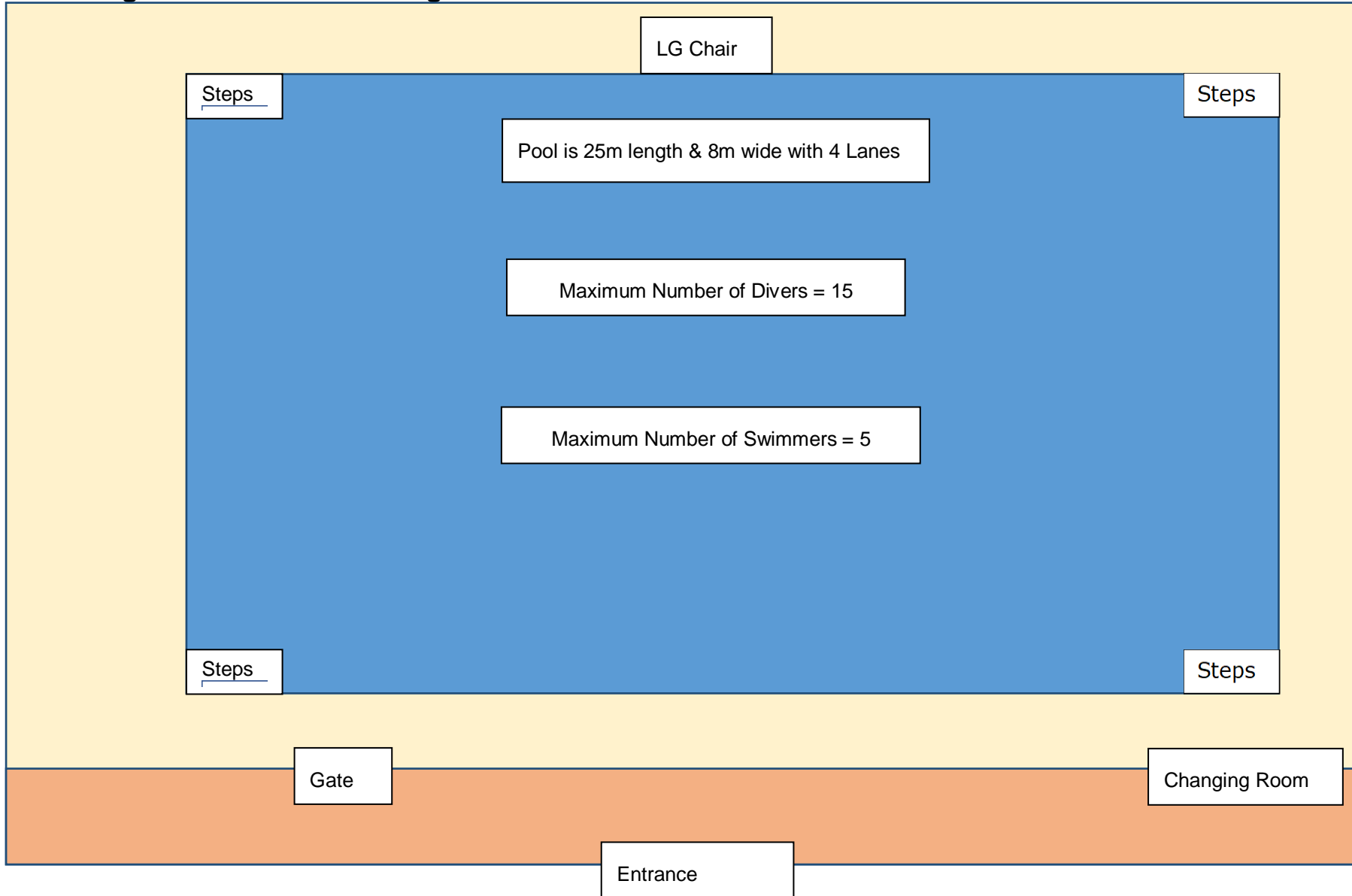

SAA Template
Swimming Pool Guidelines

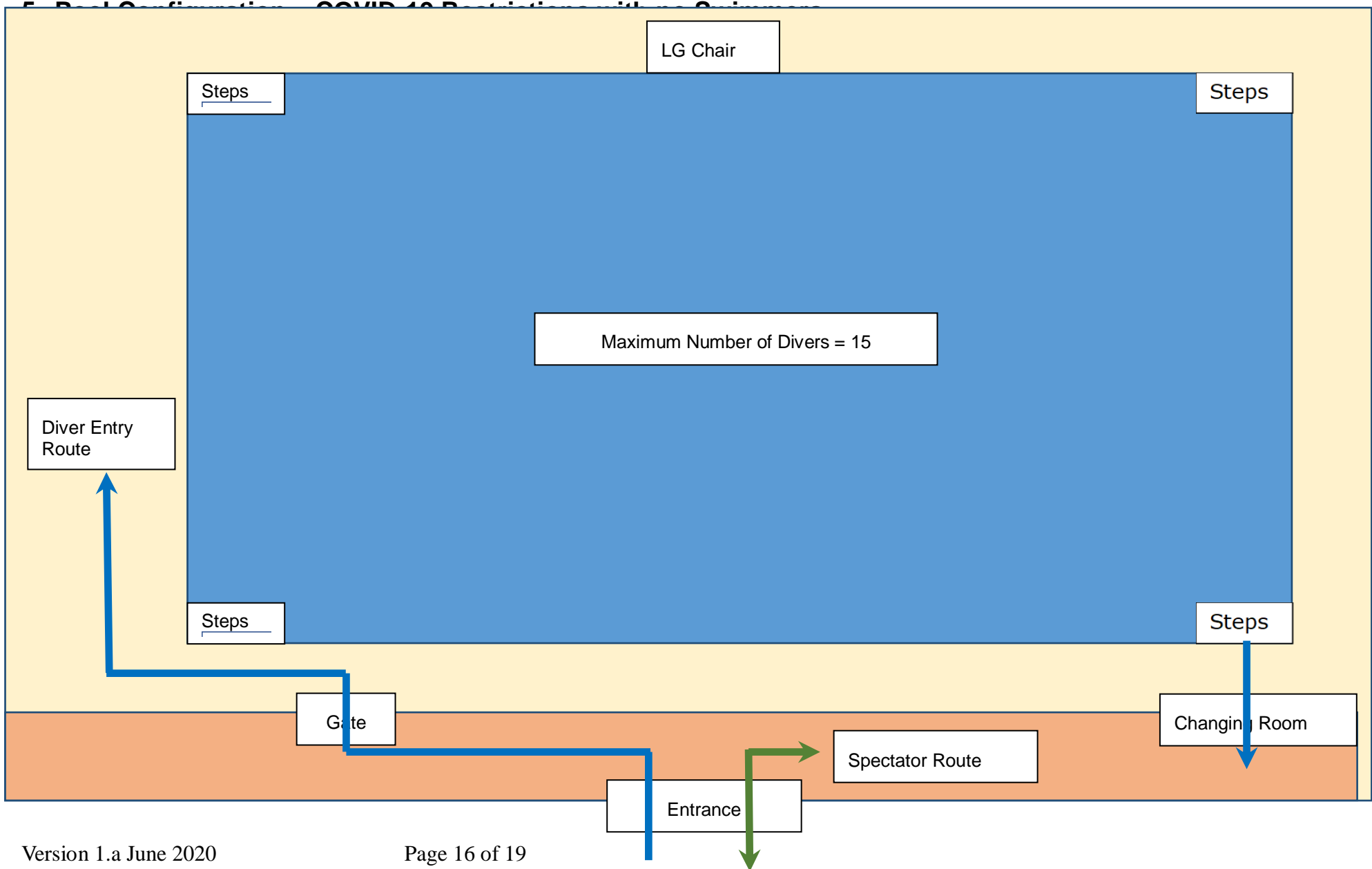

SAA Template
Swimming Pool Guidelines



6. Pool Configuration – COVID-19 Restrictions with Swimmers

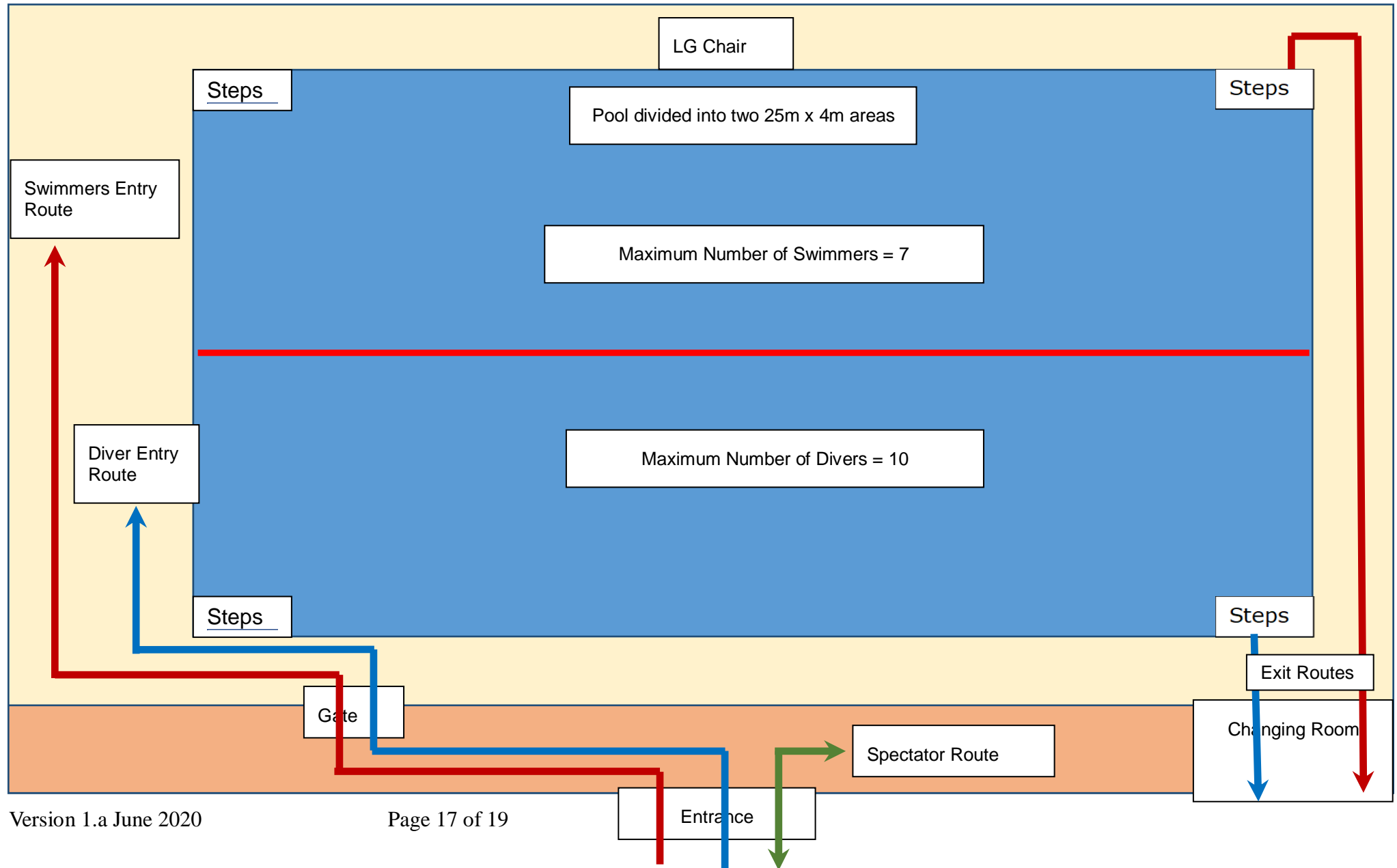



SAA Template

Swimming Pool Guidelines

7. Poolside Storage of Club Equipment

Detail any arrangement in place if equipment is stored at the pool



SAA Template

Swimming Pool Guidelines

8. Swimming Pool – Operating Procedures

This section should include extracts from your pool Normal Operating and Emergency Operating procedures which relate directly with sub aqua activities.